



HIGH-QUALITY

# LRPC STRANDS

FOR INFRASTRUCTURE









## OUR WORLD

Usha Martin is one of the leading global manufacturers of Low Relaxation Prestressed Concrete (LRPC) strands, which are extensively used worldwide across different applications to withstand dynamic load and impart structural stability to technology-driven projects. At Usha Martin, through continuous investments in technology, innovations, and state-of-art manufacturing, we have developed many new varieties of LRPC strands including Galvanised, Polymer-coated, Compacted & Indented LRPC to keep pace with new concepts and applications. Usha Martin offers LRPC strands of all available sizes and grades in conformance with major national and international specifications.

Apart from bright LRPC strands, we produce galvanized LRPC strands that provide additional protection against extremely corrosive environments. Galvanization increases the resistance to corrosion-led fatigue thereby resulting in enhanced service life. Usha Martin's extensive background in cable sheathing technology and extrusion capability enables us to offer LRPC products with a smooth, uniform, and concentric coating of premium quality polymers. We specialise in manufacturing high-performance Polymer Coated Grease Filled Un-Bonded LRPC Strands for post-tensioning jobs and Polymer Coated Bonded LRPC Strands for stay cables applications.

Usha Martin has over six decades of rich experience in manufacturing and supplying prestressing machines & accessories, backed up by the expert installation team for pre-tensioning and post-tensioning jobs. Our prestressing solutions include system design, supply of different LRPC strands, anchorage accessories & necessary prestressing equipment used worldwide in various civil engineering projects & applications like bridges, elevated structures, metros, flyovers, silos, nuclear reactors, very high-capacity water tanks in deserts, dams, rock & ground anchoring, etc.

We are the only company that offers complete prestressing solutions with supply capabilities for all the required components, backed by a specialized service team. Our service-focused model has elevated Usha Martin as a one-stop solution provider, in addition to supplying high-performance, value-added LRPC products for our customers. Our infrastructural facilities are equipped with the latest state-of-the-art technology and high-capacity machines to manufacture world-class products and provide uninterrupted services to our customers worldwide through our global network.

# GLOBAL FOOTPRINT



**60+** YEARS OF LEADERSHIP



PRESENCE ACROSS

**75+**  
COUNTRIES



**06** MANUFACTURING FACILITIES



**02** R&D CENTRES



**300+**  
CHANNEL PARTNERS





# OUR CAPABILITIES

## MANUFACTURING EXCELLENCE

State-of-the-art machineries to produce all variants of LRPC including compacted and indented LRPC.

Dedicated plastication line for value-added LRPC, both for wax-filled and grease-filled LRPC.

Galvanization facility for ensuring corrosion protection.

CNC machines for manufacturing anchorage accessories.

State-of-the-art heat treatment facilities for anchorages.

High precision pre-stressing equipment manufacturing setup.

## PRODUCT BASKET

- Galvanized LRPC strand.
- Polymer coated Galvanized/  
Bright LRPC strand.
- Wax Filled - Bonded LRPC strand.
- Grease Filled - Unbonded LRPC strand.
- Indented LRPC strand.
- Compacted LRPC strand.

## IN-HOUSE TESTING FACILITY

- Fatigue test.
- Relaxation test.
- Angled breaking force test  
(Deflected tensile test).
- Breaking load test.
- Dynamic water tightness test.
- Static water tightness test.
- Impact test.
- Bond test.
- Chemical analysis.





## ONE-STOP SOLUTION PROVIDER

More than six decades of expertise in offering:

- LRPC strands - all variants as per project requirement.
- Anchorages.
- Prestressing equipment.

Dedicated team for executing prestressing turnkey jobs for:

Bridges, flyovers, ROBs, silos, metro rail viaduct, post tension slabs, nuclear reactors and many other heavy civil projects.







# BUILDING THE ADVANCED INFRASTRUCTURE WITH HIGH QUALITY **LRPC STRANDS**



Dam





Bridge



Airport



Metro Rail



Nuclear Power Plant



Cement Silo



Windmill



# PRODUCT SPECIFICATIONS

## IS 14268 : 2022

Strand Designation	Diameter	Tensile Strength	Cross Sectional Area	Mass/Metre	Tolerance on Nominal Mass/Metre	MBL	Min 0.2% Proof Load	Total Elongation at min. CL = 600mm	Max Relaxation at initial force equals to 70% of specified MBL	
									100 Hours	1000 Hours
	mm	Mpa	mm <sup>2</sup>	g/m	%	kN	kN	%	%	%
9.3-1770-P	9.3	1770	52	406.1	± 2	92.00	81.00	≥ 3.5	≤ 1.8	≤ 2.5
9.6-1770-P	9.6	1770	55	429.6	± 2	97.40	85.70			
11.0-1770-P	11	1770	70	546.7	± 2	124.00	109.00			
12.5-1770-P	12.5	1770	93	726.3	± 2	165.00	145.00			
12.7-1770-P	12.7	1770	100	781.0	± 2	177.00	156.00			
15.2-1770-P	15.2	1770	139	1086.0	± 2	246.00	216.00			
15.7-1770-P	15.7	1770	150	1172.0	± 2	266.00	234.00			
18.0-1770-P	18	1770	200	1562.0	± 2	354.00	312.00			
9.3-1860-P	9.3	1860	52	406.1	± 2	96.70	85.10	≥ 3.5	≤ 1.8	≤ 2.5
9.6-1860-P	9.6	1860	55	429.6	± 2	102.00	89.80			
11.0-1860-P	11	1860	70	546.7	± 2	130.00	114.00			
11.3-1860-P	11.3	1860	75	585.8	± 2	140.00	123.00			
12.5-1860-P	12.5	1860	93	726.3	± 2	173.00	152.00			
12.9-1860-P	12.9	1860	100	781.0	± 2	186.00	164.00			
13.0-1860-P	13	1860	102	796.6	± 2	190.00	167.00			
15.2-1860-P	15.2	1860	139	1086.0	± 2	259.00	228.00			
15.7-1860-P	15.7	1860	150	1172.0	± 2	279.00	246.00			
9.3-1960-P	9.3	1960	52	406.1	± 2	102.00	90.80	≥ 3.5	≤ 1.8	≤ 2.5
9.6-1960-P	9.6	1960	55	429.6	± 2	108.00	96.10			
11.0-1960-P	11	1960	70	546.7	± 2	137.00	122.00			
11.3-1960-P	11.3	1960	75	585.8	± 2	147.00	131.00			
12.5-1960-P	12.5	1960	93	726.3	± 2	182.00	162.00			
12.9-1960-P	12.9	1960	100	781.0	± 2	196.00	174.00			
13.0-1960-P	13	1960	102	796.6	± 2	200.00	178.00			
15.2-1960-P	15.2	1960	139	1086.0	± 2	272.00	242.00			
15.7-1960-P	15.7	1960	150	1172.0	± 2	294.00	262.00			
11.3-2060-P	11.3	2060	75	585.8	± 2	155.00	138.00	≥ 3.5	≤ 1.8	≤ 2.5
12.5-2060-P	12.5	2060	93	726.3	± 2	192.00	171.00			
12.9-2060-P	12.9	2060	100	781.0	± 2	206.00	183.00			
15.2-1860-C	15.2	1820	165	1289.0	± 2	300.00	264.00	≥ 3.5	≤ 1.8	≤ 2.5
12.7-1860-C	12.7	1860	112	874.7	± 2	208.00	183.00			
15.2-1860-C	15.2	1860	165	1289.0	± 2	307.00	270.00			

**Note:**

“P” denotes Plain.

“C” denotes Compacted.

Other than above variants, “Indented” variant is also available.



# ASTM A416 / A416M : 2018 [Grade 270 (1860)]

Nominal Diameter	MBL	Cross Sectional Area	Weight of Strand	Minimum Load of 1% Extension	Mass	Initial Load	Total Elongation at min. GL = 600mm	Relaxation properties at 1000 hrs for initial force corresponding to	
								70% of MBL	80% of MBL
Inch (mm)	lbf (kN)	inch <sup>2</sup> (mm <sup>2</sup> )	lb/1000f (kg/1000m)	lbf (kN)	lb/ft (kg/km)	lbf (kN)	%	%	%
0.375 (9.53)	23000 (102)	0.085 (55)	290 (430)	20700 (92.1)	290 (430)	2300 (10.2)	≥ 3.5	≤ 2.5	≤ 3.5
0.438 (11.10)	31000 (138)	0.115 (74.2)	390 (580)	27900 (124.1)	390 (580)	3100 (13.8)			
0.500 (12.70)	41300 (184)	0.153 (98.7)	520 (780)	37170 (165.3)	520 (780)	4130 (18.4)			
0.600 (15.20)	58600 (261)	0.217 (140)	740 (1100)	52740 (234.6)	740 (1100)	5860 (26.1)			
0.620 (15.70)	62800 (279)	0.231 (150)	780 (1200)	56520 (251.4)	780 (1200)	6280 (27.9)			

## BS 5896:2012

Steel Number	Steel Name	Diameter	Tensile Strength	Cross Sectional Area	Mass/ Metre	Permissible value of deviation Mass/ Metre	Characteristic Value of Maximum Force	Maximum Value of Maximum Force	Total Elongation at min. GL ≥ 500mm	Characteristic Value of 0.1% Proof Force	Relaxation properties at 1000 hrs for initial force corresponding to	
											70% F <sub>ma</sub>	80% F <sub>ma</sub>
		mm	Mpa	mm <sup>2</sup>	g/m	%	kN	kN	kN	%	%	%
1.1365	Y1770S7	9.3	1770	52	406.1	± 2	92	106	81	≥ 3.5	≤ 2.5	≤ 4.5
1.1365	Y1770S7	11	1770	70	546.7	± 2	124	143	109			
1.1365	Y1770S7	12.5	1770	93	726.3	± 2	165	190	145			
1.1365	Y1770S7	15.7	1770	150	1172	± 2	266	306	234			
1.1366	Y1860S7	9.3	1860	52	406.1	± 2	96.7	111	85.1	≥ 3.5	≤ 2.5	≤ 4.5
1.1366	Y1860S7	9.6	1860	55	429.6	± 2	102	117	89.8			
1.1366	Y1860S7	11.3	1860	75	585.8	± 2	140	161	123			
1.1366	Y1860S7	12.5	1860	93	726.3	± 2	173	199	152			
1.1366	Y1860S7	12.9	1860	100	781	± 2	186	214	164			
1.1366	Y1860S7	15.2	1860	139	1086	± 2	259	298	228			
1.1366	Y1860S7	15.7	1860	150	1172	± 2	279	321	246			
1.1370	Y1700S7G	18	1700	223	1742	± 2	379	436	334	≥ 3.5	≤ 2.5	≤ 4.5
1.1371	Y1820S7G	15.2	1820	165	1289	± 2	300	345	264			
1.1372	Y1860S7G	12.7	1860	112	875	± 2	208	239	183			

## prEN 10138-3 : 2006

Steel Name	Steel Number	Diameter d	Nominal			Specified				Total Elongation	Relaxation properties at 1000 hrs for initial force corresponding to	
			Tensile Strength R <sub>m</sub>	Cross Sectional Area S <sub>n</sub>	Mass/ Metre M	Permitted Deviation on Mass/ Meter	Characteristic Value of Maximum Force F <sub>m</sub>	Maximum Value of Maximum Force F <sub>m,max</sub>	Characteristic Value of 0.1% proof force F <sub>p0.1</sub>		70% F <sub>ma</sub>	80% F <sub>ma</sub>
		mm	Mpa	mm <sup>2</sup>	g/m	%	kN	kN	kN	%	%	%
Y1860S7	1.1366	9	1860	50	390.5	± 2	93	107	81.8	≥ 3.5	≤ 2.5	≤ 4.5
		11	1860	70	546.7	± 2	130	150	114			
		12.5	1860	93	726.3	± 2	173	199	152			
		12.9	1860	100	781	± 2	186	214	164			
		15.2	1860	139	1086	± 2	259	298	228			
		15.7	1860	150	1172	± 2	279	321	246			
Y1770S7	1.1365	12.5	1770	93	726.3	± 2	165	190	145	≥ 3.5	≤ 2.5	≤ 4.5
		12.9	1770	100	781	± 2	177	204	156			
		15.2	1770	139	1086	± 2	246	283	216			
		15.7	1770	150	1172	± 2	266	306	234			



# PRODUCT SPECIFICATIONS

## JIS G 3536 : 2014

Symbol	Designation	Test Force for 0.2% Permanent Elongations	Max. Test Force	Min. Elongation	Diameter	Tolerance	Nominal Sectional Area	Unit Mass	Total Elongation	Relaxation properties at 1000 hrs for initial force corresponding to
		kN	kN	%						mm
SWPR7BL	9.5 mm 7 Wire Strand	86.8	102	3.5	9.5	(+0.4) to (-0.2)	54.84	432	≥ 3.5	≤ 2.5
	11.1 mm 7 Wire Strand	118	138		11.1		74.19	580		
	12.7 mm 7 Wire Strand	156	183		12.7		98.71	774		
	15.2 mm 7 Wire Strand	222	261		15.2		138.7	1101		

## ISO 6934-4:2020

Type of Strand	Nominal Strand Diameter	Nominal Tensile Strength	Nominal Cross Sectional Area	Mass Per Length		Characteristic			Total Elongation at min. GL = 600mm	Relaxation properties at 1000 hrs for initial force corresponding to	
				Nominal	Permissible deviation	Characteristic Value of Max. Force	Characteristic Value of 0.1% Proof Force	Characteristic Value of 0.2% Proof Force		70% F <sub>ma</sub>	80% F <sub>ma</sub>
7 Wire Ordinary	9.5	1860	54.8	432	(+) to (-)	102	83.6	88.6	≥ 3.5	≤ 1.8	≤ 2.5
	10.8	1720	69.7	546		120	98.4	102			
	11.1	1860	74.2	580		138	113	117			
	12.4	1720	92.9	729		160	131	136			
	12.7	1860	98.7	774		184	151	156			
	15.2	1720	139	1101		239	196	203			
	15.2	1860	139	1101		259	212	220			

## AS/NZS 4672.2:2007

Type of Strand	Nominal Strand Diameter	Nominal Tensile Strength	Nominal Cross Sectional Area	Mass Per Length		Characteristic			Total Elongation at min. GL ≥ 500mm	Relaxation properties at 1000 hrs for initial force corresponding to	
				Nominal	Permissible deviation	MBL	Characteristic Value of 0.1% Proof Force	Characteristic Value of 0.2% Proof Force		70% F <sub>ma</sub>	80% F <sub>ma</sub>
7 Wire Ordinary	9.3	1720	51.6	405	(+) to (-)	88.8	72.8	75.4	≥ 3.5	≤ 2.5	≤ 3.5
	10.8	1720	69.6	546		120	98.4	102			
	11.1	1870	73.9	580		138	113	117			
	12.4	1720	92.9	729		160	131	136			
	12.9	1840	100	785		186	158	165			
	15.2	1790	140	1101		250	205	212			
	15.2	1860	140	1101		261	214	222			





# USHA MARTIN'S LRPC STRANDS

## THE PREFERRED CHOICE FOR BRIDGE DESIGNERS





# MANUFACTURING OF POLYMER COATED **WAX-FILLED AND GREASE-FILLED LRPC**





HIGH PERFORMANCE  
POLYMER-COATED **LRPC STRANDS**



# VALUE ADDED LRPC PRODUCTS

Usha Martin product basket encompasses a comprehensive range of value-added LRPC strands, apart from the conventional strands, namely

- **Galvanized LRPC Strand.**
- **Wax-Filled Bonded PE Coated LRPC Strand.**
- **Polymer Coated Galvanized\* / Bright LRPC Strand.**
- **Grease-Filled Unbonded PE Coated LRPC Strand.**
- **Indented LRPC Strand.**
- **Compacted LRPC Strand.**

\*LRPC Strands of all available sizes and grades can be polymer sheathed and galvanized in conformance to all national and international specifications.

## GALVANIZED / BRIGHT LRPC STRAND

Apart from bright LRPC strand for some applications, particularly in case of extremely corrosive environment, Usha Martin's Galvanized LRPC strands provide the additional protection required and can be manufactured as per International Standards.

The physical and mechanical properties of the galvanized strands manufactured from hot-dip galvanized wires are at par with the bright strands for that diameter. Galvanization increases the resistance to corrosion-led fatigue thereby resulting in enhanced service life.



## POLYMER COATED GALVANIZED / BRIGHT LRPC STRAND

The extruded thermoplastic coating becomes an integral part of the strand and is highly recommended for the construction industry. The coating seals out contaminants, cushions the strands, resists abrasion and increases the life cycle of the structure. Usha Martin's extensive background in cable sheathing technology and extrusion capability facilitates products with a smooth, uniform and concentric coating of polymer with premium quality. Usha Martin offers a selection of choices of types (family), thickness and colours (UV stabilized) of Polymers suitable for LRPC strand sheathing.



## POLYMER COATED UNBONDED LRPC STRAND FOR POST TENSIONING

This LRPC Strand may be bright or galvanized depending upon the environment, is coated with a corrosion resistant / water repellent – high temperature grease to fill the interstices between the wires followed by a co-extrusion of a UV stabilized Polymer layer with the thickness (min 0.5 mm, max as per customer's requirement).

Usha Martin's Un-bonded LRPC strands have excellent durability and provide perfect protection against corrosion due to complimentary nested barriers formed by galvanization followed by anti-corrosion, water repellent - grease/wax coating in the interstices and finally the UV stabilized polymer sheath, extruded onto the LRPC Strand. This particular arrangement also enables monitoring of strands, by replacing a post-tensioned strand at regular intervals. This variant is more prevalent in the building PT and other constructional segments involving external post tensioning.

### The salient characteristics of the product

- Mechanical properties of the steel strand.
- Diameter & thickness consistency of the sheath.
- Anti-corrosion property & lubricating property of the filler compound.
- Sheathing profile.



## POLYMER COATED BONDED LRPC STRAND (GALVANIZED / BRIGHT)

Bonding implies adhesion of the polymer sheath with the steel surface of the LRPC Strand. Bonded LRPC Strands exhibits a strong bonding strength and conforms to the requirement of the customers. The state-of-art of sheathing lines and stringent control parameters during manufacturing particularly with regard to diametrical concentricity of the sheathing, consents bridge designers to bundle Usha Martin strands with confidence.

# THE SALIENT CHARACTERISTICS OF THE PRODUCT:

## Superior mechanical properties of the steel strand:

- Fatigue property.
- Relaxation property.
- Angled breaking force (Deflected tensile).
- Cryogenic test.
- Stress-corrosion test.

## Properties of the anti-corrosion filler (wax) compound:

- Congealing point.
- Cone penetration.
- Operating temperature range.
- Oxidation stability.
- Corrosion protection.
- Compatibility with sheathing.
- Dropping point.

## Properties of the engineering polymer:

- Melt flow index.
- Density.
- Carbon black (Content / Dispersion / Distribution).
- Tensile strength (ambient & sub-zero temp).
- Thermal stability.
- UV stability.
- Environmental stress cracking resistance.

Usha Martin can produce stay cable strands as per fib 89, PTI regulation and any applicable national & international standards.

**Indented LRPC Strand** compared to normal/plain LRPC adheres strongly with the concrete & can transfer the desired compressive force from the steel strand to the concrete. Usha Martin can produce indentation patterns as per applicable national & international standards.

**Compacted LRPC Strand** is produced through a special process called “compaction” by virtue of which there is more steel in a given length & has very high load bearing capacity. These are used in heavy lifting applications. Usha Martin can produce Compacted LRPC (“G”) as per applicable national & international standards.





# OUR SERVICES

## PRESTRESSING SOLUTIONS

Usha Martin's ISMAL wing is the pioneer and leader in offering complete prestressing solutions.

Pre-stressing activities require the supply of anchorages, LRPC strands, and on-site stressing services. Pre-stressing encompasses pre-tensioning & post-tensioning for both internal and external systems. Usha Martin has a widespread set-up for undertaking all types of pre-stressing jobs. Pre-stressing activities generally comprise profiling the pre-stressing tendon at the time of casting, stressing on achieving the strength of the cast structure, and grouting to remove the void spaces, thus making the tendon integral to the cast structure.

All the above activities are executed by UML expert site personnel using sophisticated hydraulic and pneumatic equipment, which are also manufactured in our state-of-the-art manufacturing plant located at Ranchi in India.

UML executed various pre-stressing activities for numerous applications like Buildings, Nuclear Reactor, Elevated Structure including Cement and Clinker Silos, Metro projects, Extra-dosed bridges, Gigantic water tanks in desert areas, Ground anchoring in Dams, Rockfall arresters, Soil Stabilization, High-speed Railway projects, and RRTS projects.

Usha Martin's service team has vast experience in executing all pre-stressing activities in many such prestigious projects both in India and abroad.





## ANCHORAGE

We are being the pioneer in pre-stressing activities and have the necessary manufacturing infrastructure for supplying all types of components required in pre-stressing operations. Our anchorages are suitable for both round and flat-type tendons. The anchorage set, comprising of a Tube Unit, Sheathing Pipe, Bearing Plate, and Ancharite Wedges are used in post-tensioning jobs; Wedge grips and barrels are used in pre-tensioning, and both are well accepted worldwide for best-in-class quality.

**Round Tendon Systems** - required in heavy civil structures like metros, flyovers, bridges, silos etc.

4T13, 5T13, 6T13, 7T13, 8T13, 9T13, 12T13, 19T13, 22T13, 27T13 - for 12.9MM LRPC strand.

---

4T15, 5T15, 6T15, 7T15, 8T15, 9T15, 12T15, 19T15, 22T15, 27T15, 31T15 - for 15.2MM LRPC strand.

**Flat Tendon Systems** - required in PSC slab projects like building projects.

3T13, 4T13, 5T13 - for 12.9mm LRPC strand.

---

3T15, 4T15, 5T15 - for 15.2MM LRPC strand.





# PRE-STRESSING ANCHORAGES WITH LRPC STRANDS

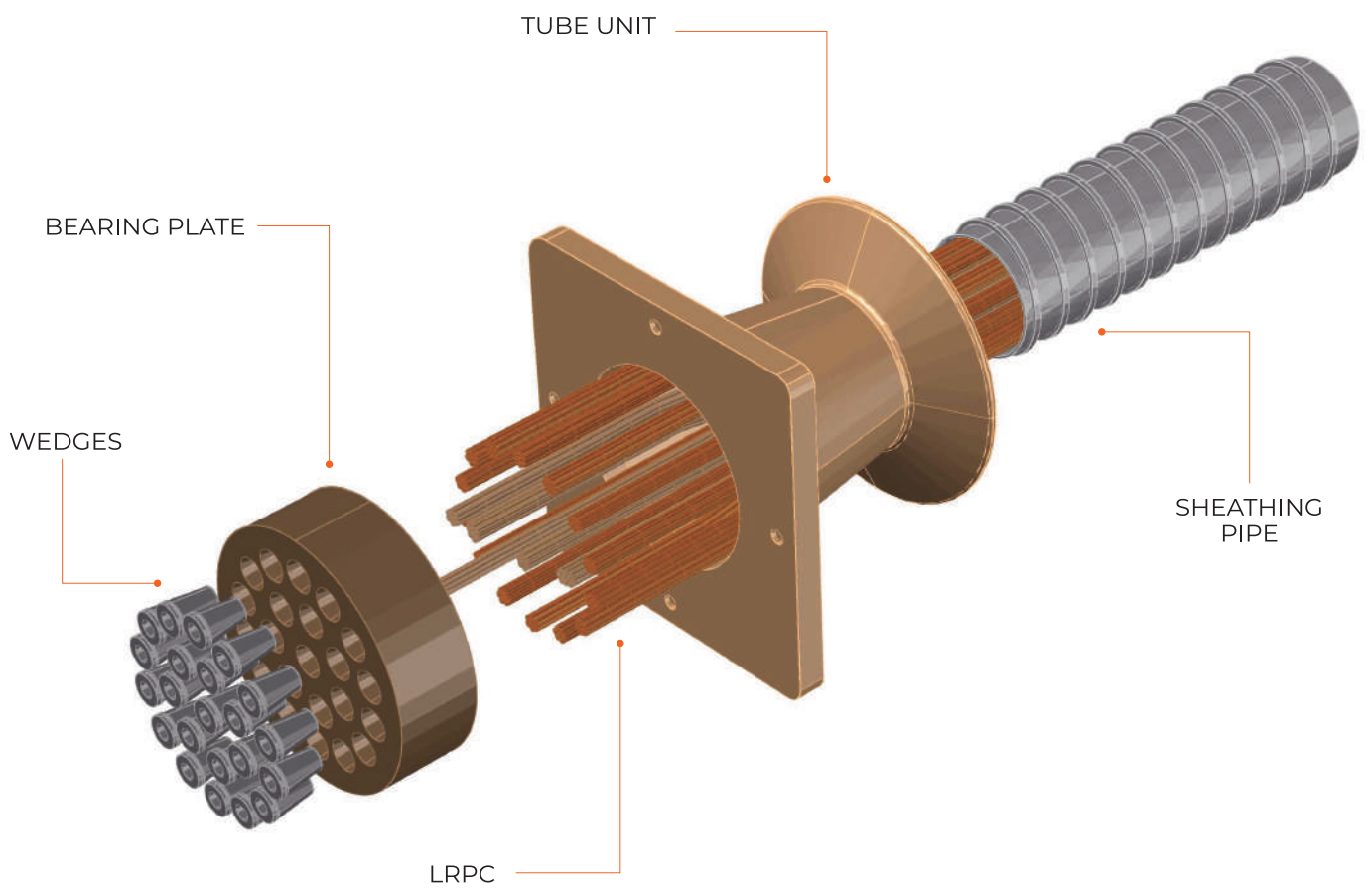

# EQUIPMENT

Pre-stressing activity calls for the deployment of various hydraulic and pneumatic equipment at the project site which have to be performed with great accuracy and time-bound performance.

## Hydraulic Jacks

Model	Capacity	Overall length	Gripping	Outer dia of main tube with pipe	Min grip length of strand/wire for Jack attachment	Max travel	Wt.
	kN	mm		mm	mm	mm	kgs
10° Extn Wire Jack	65	610	Rear	130	700	250	10
20° Extn Wire Jack	65	915	Rear	130	1000	500	15
J-20 Strand Jack	220	735	Front	170	350	200	28
J-20 Extra Long S. Jack	220	935	Front	170	350	400	37
J-30 Strand Jack	300	735	Front	220	350	200	48
J-30 Extra Long S. Jack	300	935	Front	220	350	400	60
1000 MG Multipull Jack	1000	615	Mid	248	500	200	110
1800 MG Multipull Jack	1800	780	Mid	342	700	210	280
4000 MG Multipull Jack	4000	805	Mid	490	750	210	540
5000 MG Multipull Jack	5000	820	Mid	545	750	210	640





## **Powerpacks**

VMP 3/2 Hydraulic Powerpack for Mono Jack.

---

VMP 5/2 Hydraulic Powerpack for Multipack Jack.

---

VMP 3/1 Hydraulic Powerpack for Wire Jack.

---

Hydraulic Press (500 & 1000 MT capacity with accessories and spares).

## **Grout Pump & Grouting Agitator**

Electric operated grout pump and agitator (mixing machine) as per specifications of prestressing.



## CORPORATE OFFICE

### USHA MARTIN LIMITED

2A, Shakespeare Sarani 'Mangal Kalash'  
Kolkata – 700 071  
Phone: +91 33 71006300 / +91 33 71006492  
Fax: +91-33-71006400  
Email: contact@ushamartin.co.in

## DOMESTIC OFFICES

### NORTH REGIONAL OFFICE

#### USHA MARTIN LIMITED

825 & 826, 8th Floor,  
World Trade Tower  
Plot-1, Block- B, Sector-16, Noida, U.P. – 201301  
Phone: +91 120 6286129  
Email: marketing-north@ushamartin.co.in

### EAST REGIONAL OFFICE

#### USHA MARTIN LIMITED

2A, Shakespeare Sarani 'Mangal Kalash'  
Kolkata – 700071  
Phone: +91 33 71006492  
Email: marketing-east@ushamartin.co.in

### SOUTH REGIONAL OFFICE

#### USHA MARTIN LIMITED

Logos Towers, No. 14, First Avenue, Ground Floor,  
Ashok Nagar, Chennai - 600083  
Phone: +91 44 47885020  
Email: marketing-south@ushamartin.co.in

### WEST REGIONAL OFFICE

#### USHA MARTIN LIMITED

Office No.1001/1002, Chandak Chambers,  
Near WEH Metro Station, Andheri Kurla Road,  
Andheri (E), Mumbai – 400 069  
Phone: +91 22 6239 0290  
Email: marketing-west@ushamartin.co.in

## OVERSEAS OFFICES

### USHA MARTIN AMERICAS, INC

701 Plastics Avenue,  
Houston Texas 77020, USA  
Phone: +171 3676 1800  
Email: sales@ushamartinus.com

### USHA MARTIN UK LIMITED

Sandy Lane, Worksop,  
Nottinghamshire, S80 3ES, UK  
Phone: +44 01909 537 645  
Email: info@ushamartin.co.uk

### EMM CORP

Howe Moss Place,  
Kirkhill Industrial Estate Dyce,  
Aberdeen AB 21 OGS, Scotland, UK  
Phone: +44 1224 77 5151  
Email: info@emmcop.com

### BRUNTON SHAW UK

Sandy Lane, Worksop, S80 3ES, UK  
Phone: + 44 1909 537 600  
Email: info@brunton-shaw.co.uk

### DE RUITER STAALKABEL B.V.

Kerkeplaat 10, 3313 LC Dordrecht  
The Netherlands  
Phone: +31 (0) 78 – 8200600  
Email: info@drstk.nl

### USHA MARTIN EUROPE B.V.

Kerkeplaat 10  
3313 LC Dordrecht The Netherlands  
Phone: +31 (0) 180 – 745099  
Email: info@ushamartineurope.com

### BRUNTON WIRE ROPES FZCo.

P.O. Box 17491, M00301  
Jebel Ali Free Zone, Dubai U.A.E  
Phone: + 971 50 4503717  
Email: sm@bsme-uae.com

### USHA SIAM STEEL INDUSTRIES PUBLIC COMPANY LIMITED

66 Q House Asoke Building,  
12th Floor, Unit 1207 Sukhumvit 21 road,  
North Klongtoey, Wattana, Bangkok 10110  
Phone: +662 261 7361- 4  
E-mail: info@ushasiam.com

### USHA MARTIN SINGAPORE PTE LIMITED

91 Tuas Bay Drive, Usha Martin Building,  
Singapore – 637307  
Phone: +65 6265 7756  
Email: sales@umsingapore.com

### USHA MARTIN AUSTRALIA PTY LTD

Sydney Office: 199, Hassall Street,  
Wetheril Park, NSW 2164  
Phone: +61 411 095 983  
Perth Office: 31 Colin Jamieson Drive,  
Welshpool WA 6106 Phone: +61 419 939 567  
Email: marketing-australia@ushamartin.co.in

### USHA MARTIN VIETNAM CO. LTD

18A, D2 Street, Ward 25,  
Binh Thanh District, Ho Chi Minh City,  
S.R Vietnam  
Phone: +84 28 3512 2209  
Email: qui@umvietnam.com.vn

### PT. USHA MARTIN INDONESIA

Konica Building 3A Floor Jl.  
Gunung Sahari Raya 78 Jakarta 10610,  
Indonesia  
Phone: +62 21 42870794  
Email: marketing-indonesia@ushamartin.co.in

### USHA MARTIN ITALIA S.R.L

Via Antonio Segni 6  
25062 Concesio (BS), Italy.  
Phone: +39 030 7741330  
Email: info@ushamartin.it

### USHA MARTIN CHINA CO. LTD.

Area D, Block 1, No 461 Huajing Road China  
(Shanghai) Pilot Free Trade Zone,  
Shanghai, China Postal code: 200131  
Phone: +65 6265 7756  
Email: yhw@umchina.com.cn

Follow us on:



www.ushamartin.com